

Truck Mounted Hydraulic Rotary Rig

# STM-20



**soilmec**   
Drilling and Foundation Equipment

# STM-20 Truck Mounted Hydraulic Rotary Rig

## APPLICATIONS

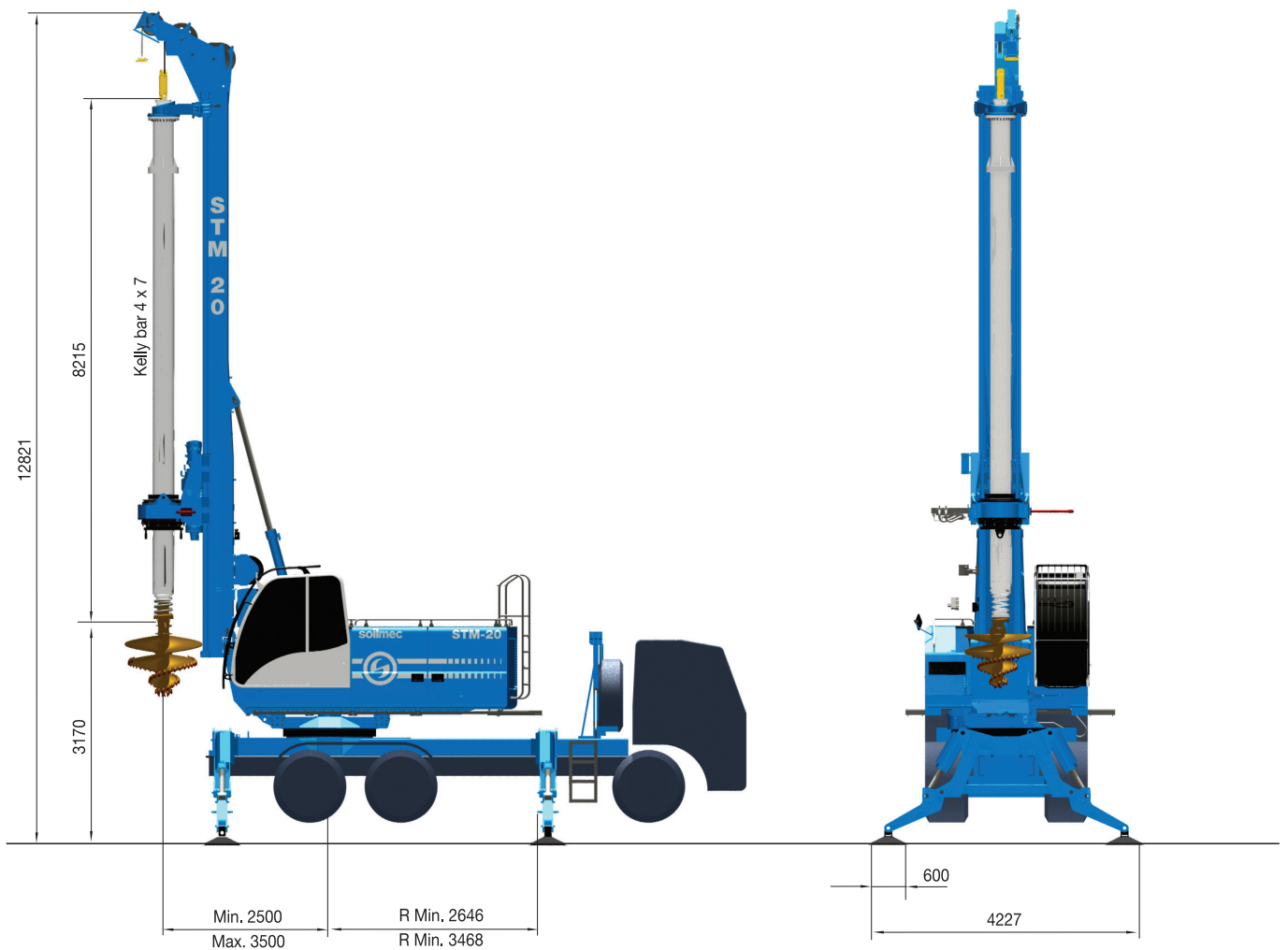

<b>LDP - Large Diameter Piles - CCS version</b>		
Operating weight (w/o tool, c/w 4x7 m kelly)	20200 kg	44533 lb
Max pile diameter in front of the mast	1100 mm	43.3 in
Max pile diameter below the mast	1800 mm	71 in
Max depth - Friction kelly	30 m	98 ft
Max depth - Locking kelly	24 m	79 ft

# STM-20 Truck Mounted Hydraulic Rotary Rig

## TECHNICAL DATA SHEET

Engine		
- Rated output SAE J1995	Cummins QSB4.5	Cummins QSB4.5
- Engine conforms to Exhaust emission Standard	119 kW @ 2200 rpm	159 HP @ 2200 rpm
- Type	EU stage III A, US EPA Tier 3 or EU stage IV, US EPA Tier 4f	EU stage III A, US EPA Tier 3 or EU stage IV, US EPA Tier 4f
- Aspiration	Turbocharged and charge air cooled	Turbocharged and charge air cooled
Rotary Drive - Spinoff type		
- Max torque ( <i>intermittent</i> )	85 kNm	62693 lbf*ft
- Rated torque	73 kNm	53842 lbf*ft
- Speed of rotation (max)	43 rpm	43 rpm
- Spinoff speed	178 rpm	178 rpm
Crowd Cylinder system		
- Crowd force pull down / pull up	85 kN / 127 kN	19019 lbf / 28558 lbf
- Stroke	1800 mm	71 in
Main winch		
	controlled descent	controlled descent
- Line pull (1st layer) nom.	102 kN	22930 lbf
- Rope diameter / Rope length	20 mm	0,79 in
- Line speed (max.)	68 m/min	223 ft/min
Auxiliary winch		
	controlled descent	controlled descent
- Line pull (1st layer)	48 kN	10701 lbf
- Rope diameter	15 mm	0.59 in
- Line speed (max.)	60 m/min	197 ft/min
Hydraulic system		
- Flow rates (main circuits)	2 x 121 l/min	2 x 32 US gal/min
Truck chassis type		
	three axles	three axles
Mast inclination		
- Max drilling rake - front / rear / side	10 ° / 10 ° / ± 5 °	10 ° / 10 ° / ± 5 °
- Levelling capability with outrigger	± 3 °	± 3 °

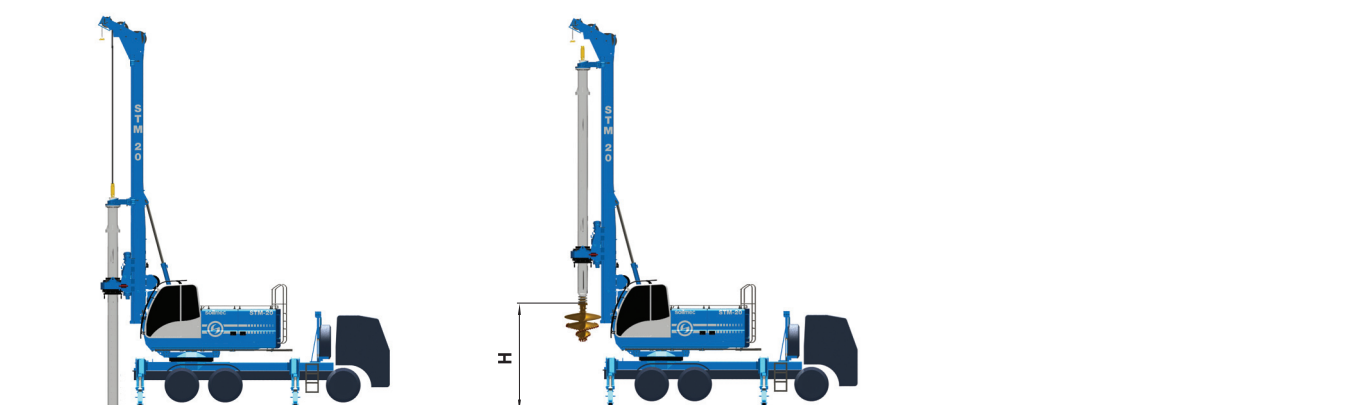

Drilling Depths	Kelly dimensions	Depth		Weight		Hcil		
		section x m	m	ft	ton	ton (US)	m	ft
3 parts	BL HD	3 x 7	17,7	58.1	2,2	2.4	4,4	14.3
	FR HD	3 x 7	18,1	59.4	1,8	1.9	4,4	14.3
4 parts	BL HD	4 x 7	24,3	79.7	2,4	2.6	4,4	14.3
	FR HD	4 x 7	24,3	79.7	2,4	2.6	4,4	14.3
5 parts	FR HD	5 x 7	30,4	99.7	3,0	3.3	4,4	14.3

# STM-20 Truck Mounted Hydraulic Rotary Rig

## TRANSPORT, DIMENSIONS AND WEIGHTS

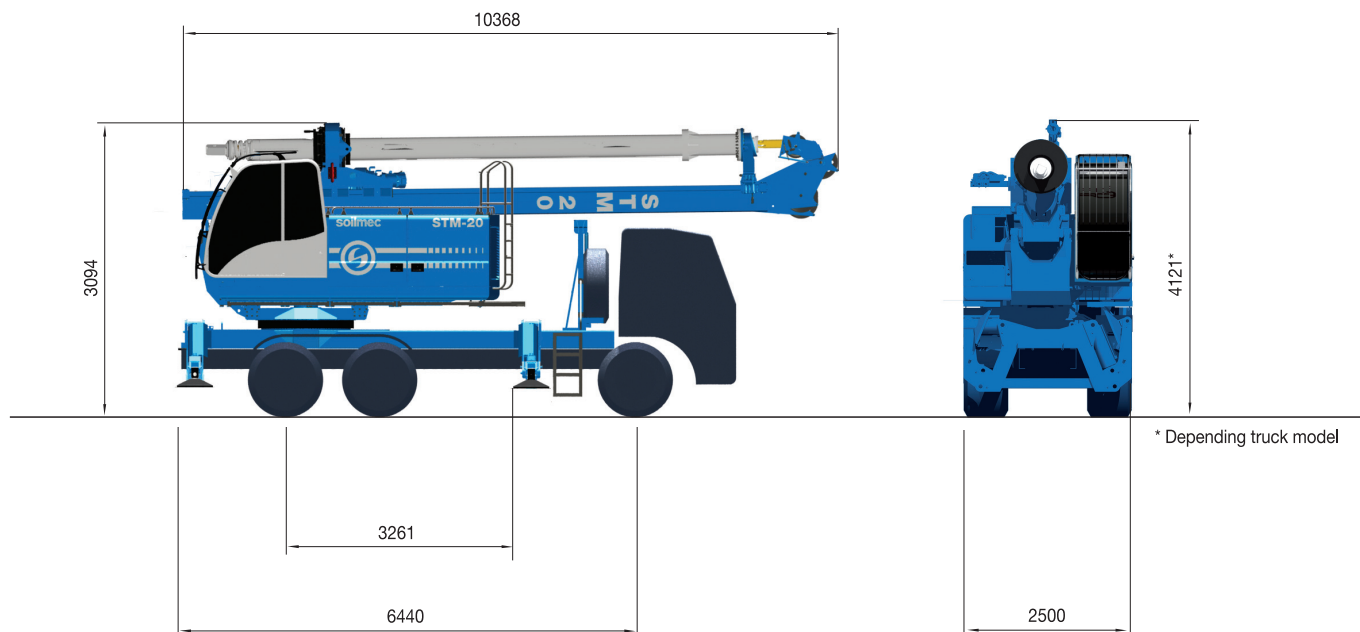

All technical data are purely indicative and subject to change without notice

### Transport with kelly

<b>Rig weight</b>	<b>20000 kg</b>	<b>44092 lb</b>
-------------------	-----------------	-----------------

Technical data sheet STM20-002 02/2016

This brochure has been edited and distributed by SOILMEC Spa. The present document cancels and override any previous ones. This brochure shall not be distributed, reproduced or exhibited without SOILMEC Spa. authorization in accordance with to SOILMEC web site disclaimer condition.

SOILMEC Spa distributes machinery and structures all over the world, supported by SOILMEC Spa subsidiary companies and dealers. The complete Soilmec network list is available on the web site [www.soilmec.it](http://www.soilmec.it)